

HARTMANN

PUMPS - MOTORS - CONTROLS

604 Progress Dr., Hartland, WI 53029 USA

Tel: (262) 367-4299

Fax: (262) 367-5645

Email: sales@hartmanncontrols.com

URL: <http://www.hartmanncontrols.com>

FRAME 1

PVX 348

(48 cm.³/rev.) (3.0 in.³/rev.)

VARIABLE DISPLACEMENT, AXIAL PISTON, SWASH PLATE DESIGN PUMP

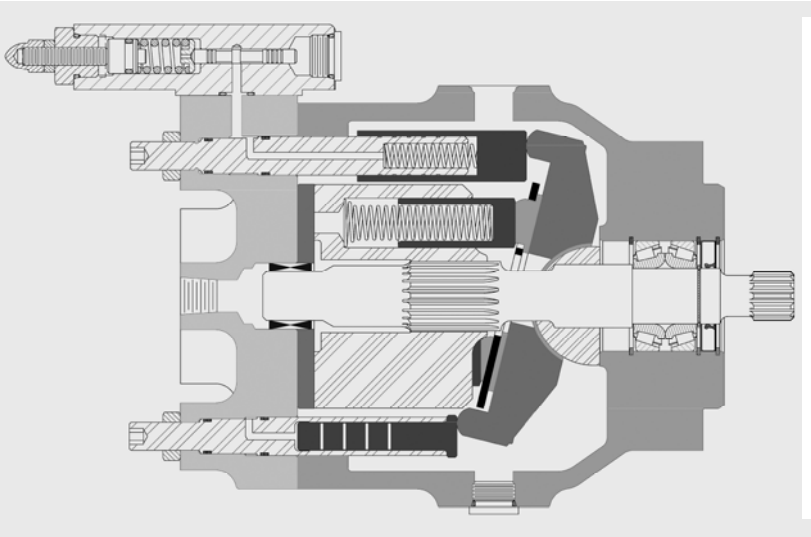

Features:

- Offered with standard SAE 'B', 2- & 4-bolt mount or SAE 'C' 4-bolt mount.
- Incorporated in a compact design with rugged ductile iron frame.
- Offered with variety of porting configurations.
- Offered with a variety of drive shaft options.
- Is Service friendly.
- Equipped with Viton shaft seal and O-rings.
- Can be fitted with a variety of control options.
- Equipped with maximum and minimum volume stops. The latter is adjustable.

This versatile PVX pump is aimed at operating in both industrial and mobile applications. With its continuous operating pressures ranging from 200 to 4500 psi, and shaft speeds up to 2800 rpm at atmospheric inlet conditions, this pump is designed for a long and dependable service.



Pumps & Motors with a hart of gold

TM

FRAME 1, PVX 348 SPECIFICATIONS

PVX	RATED PRESSURE	PEAK PRESSURE	MINIMUM PRESSURE	
348	4500 lb/in ² (310 bar)	5500 lb/in ² (379 bar)	200 lb/in ² (14 bar)	
PVX	DISPLACEMENT	THEORETICAL FLOW @ 1800 rpm	SHAFT SPEED	
			MAXIMUM	MINIMUM
348	3.0 in ³ /rev (48 cm ³ /rev)	22.0 gal/min (83.0 l/min)	2800 rpm	600 rpm
PVX	OUTPUT TORQUE @ RATED PRESSURE	SHAFT SIZE	RECOMMENDED TORQUE LIMIT	
348	2,022 in-lb (230.0 N-m)	SAE B SAE BB SAE C	1,450 in-lb (163.0 N-m) 2,200 in-lb (248.0 N-m) 3,700 in-lb (417.0 N-m)	

Input-shaft torque may not exceed the total of front-pump torque and (if added) rear-mounted units.

MODEL SPECIFICATION CHART

PVX

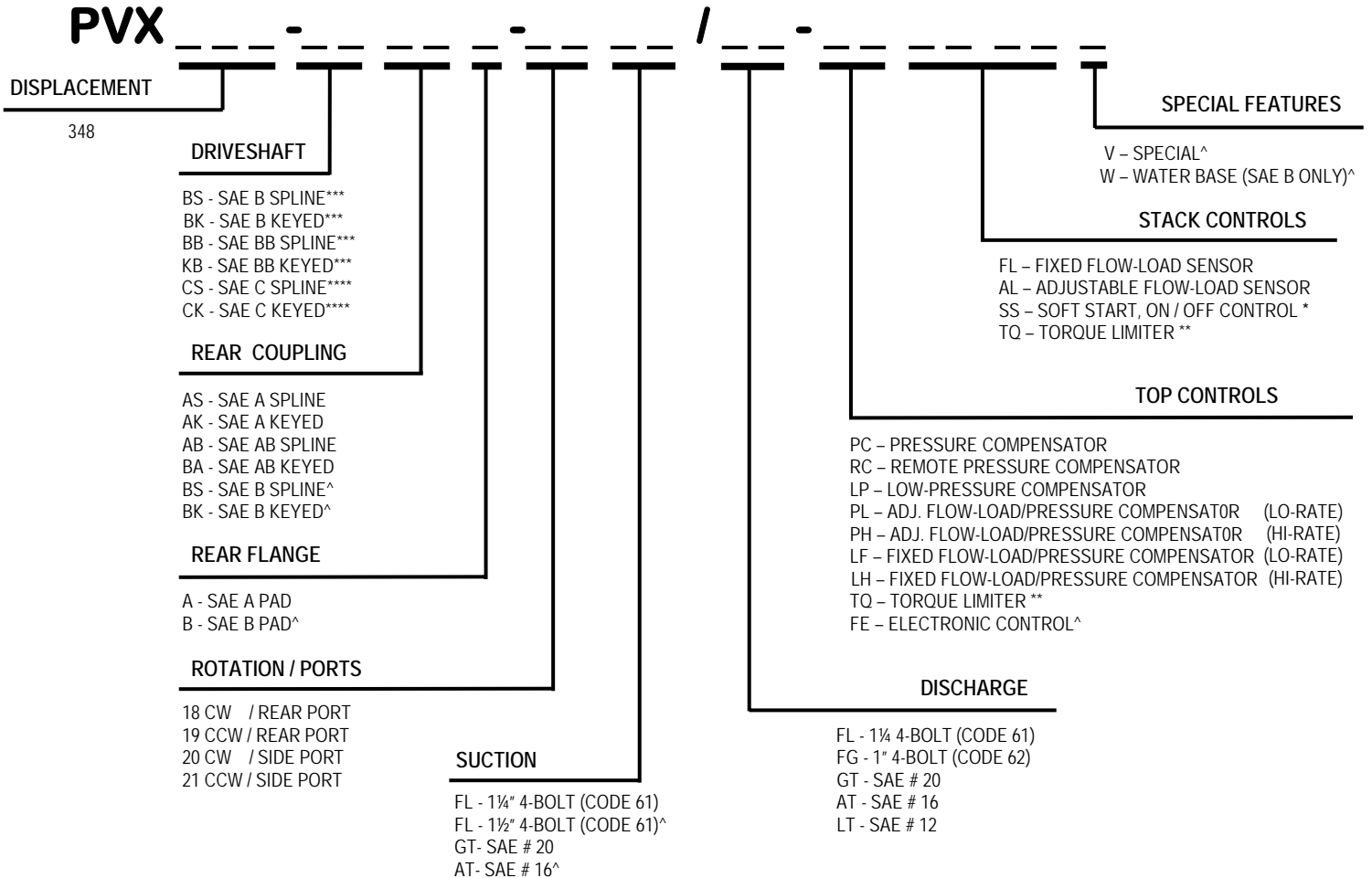

* - SPECIFY VOLTAGE, CONNECTION AND ENERGIZE OPTION

** - SPECIFY TERMINAL PRESSURE AND HORSE POWER

^ - CONSULT FACTORY

*** - MUST BE USED WITH SAE B MOUNT

**** - MUST BE USED WITH SAE C MOUNT

FRAME 1, PVX 348 PERFORMANCE

PVX348 pump performance @ 1750 rpm using ISO 32 oil at 115° F

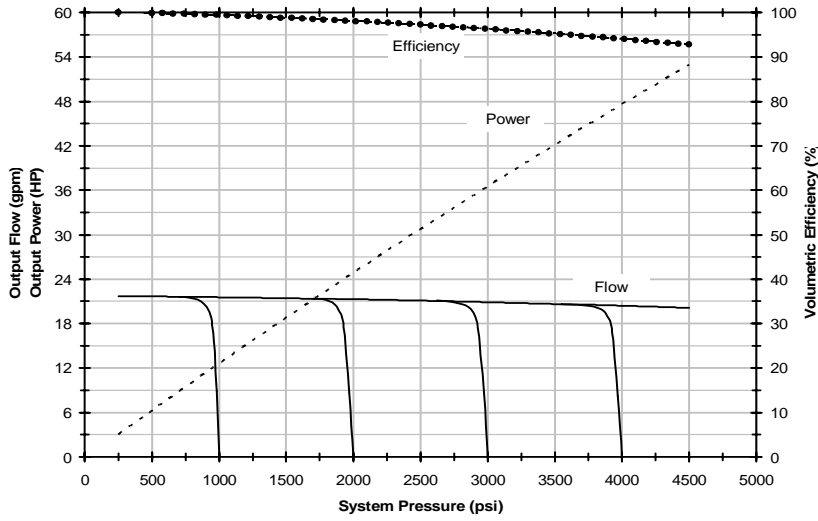

PVX348 pump input power curves @ 1750 rpm using ISO 32 oil at 115° F

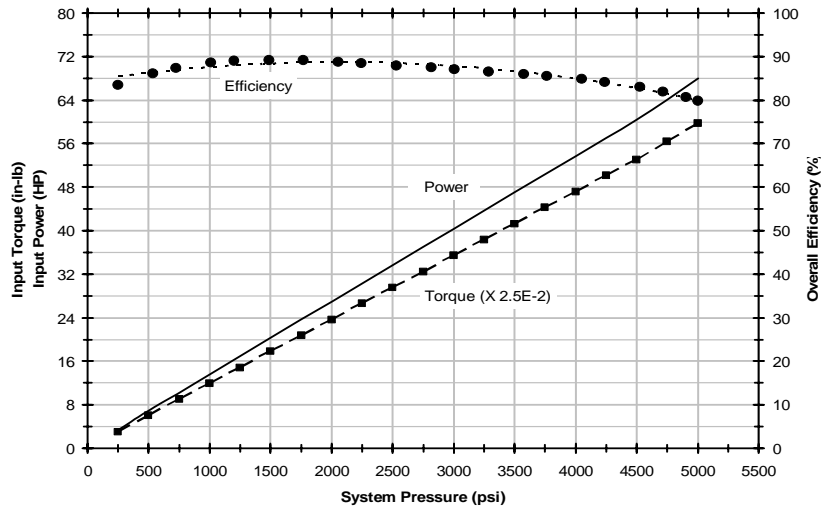

PVX348 pump inlet characteristics based on ISO 32 Oil @ 115°F

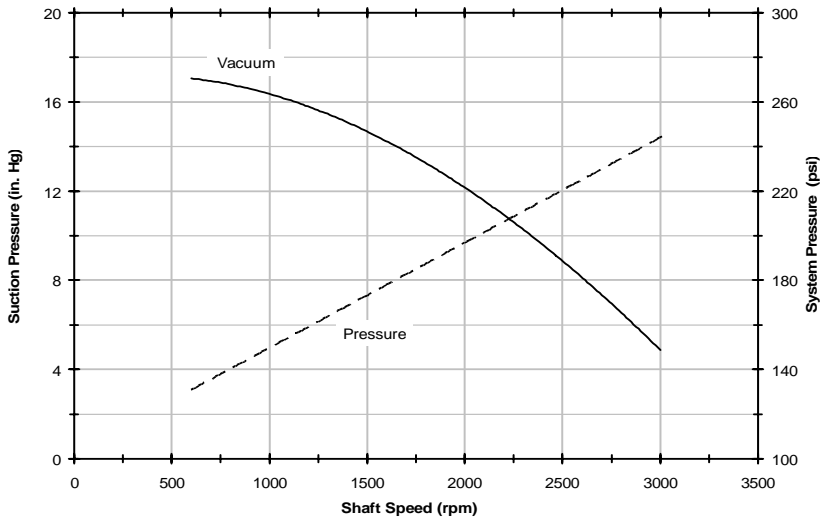

Pump typical weight: Side-Ported 68 lbs. Rear-Ported 62 lbs.

FRAME 1, PVX 348 DIMENSIONS

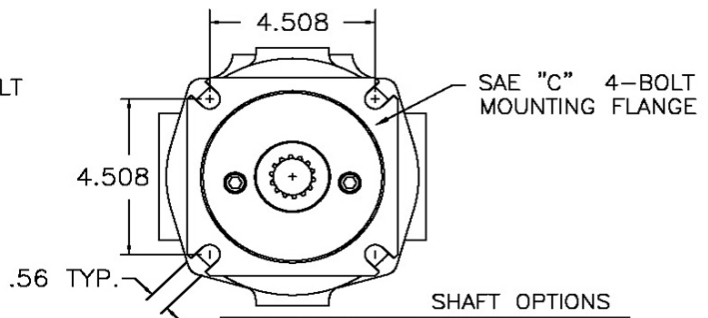
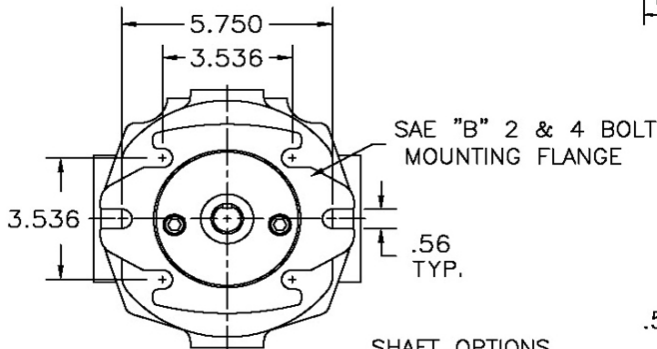
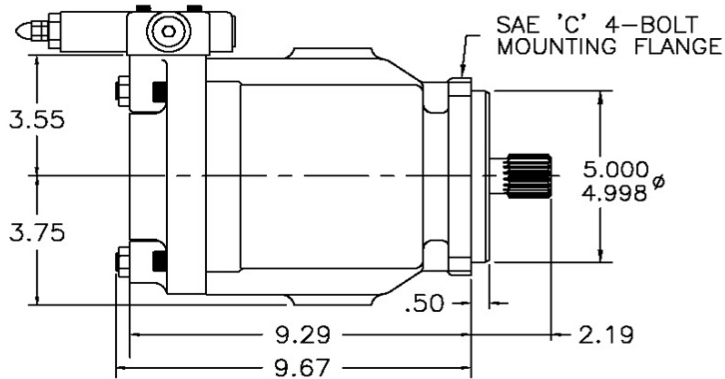
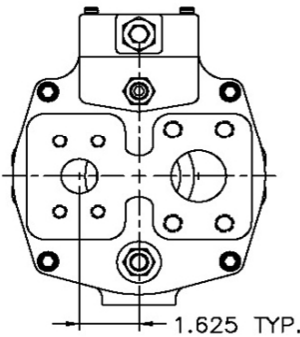
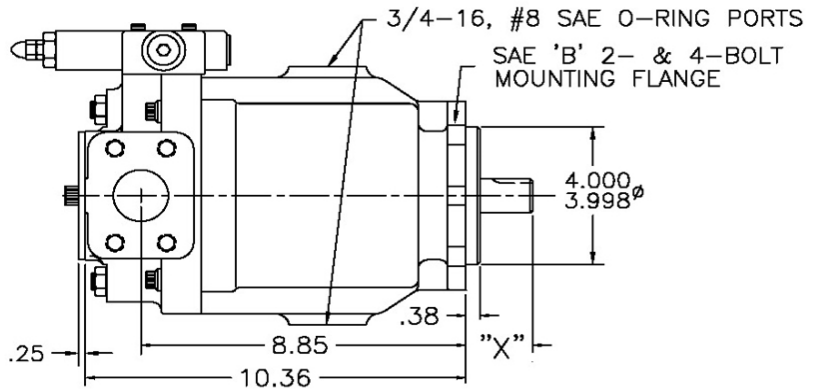
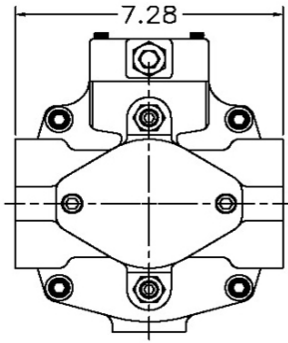

SHAFT OPTIONS

SAE SHAFT	DESCRIPTION	"X"
BB KEYED	1.000 ϕ , 1/4 SQ. KEY	1.81
BB SPLINE	15 T, 16/32 DP	1.81
B KEYED	.875 ϕ , 1/4 SQ. KEY	1.62
B SPLINE	13 T, 16/32 DP	1.62

SHAFT OPTIONS

SAE SHAFT	DESCRIPTION
C KEYED	1.250 ϕ , 5/16 SQ. KEY
C SPLINE	14 T, 12/24 DP

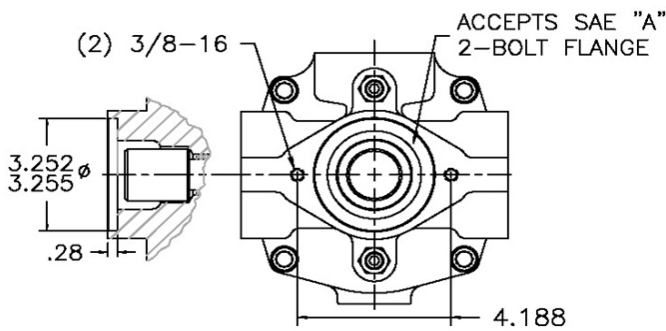

SAE SHAFT	DESCRIPTION
A KEYED	.625 ϕ , 5/32 SQ. KEY
A SPLINE	9 T, 16/32 DP
AB KEYED	.750 ϕ , 3/16 SQ. KEY
AB SPLINE*	11 T, 16/32 DP

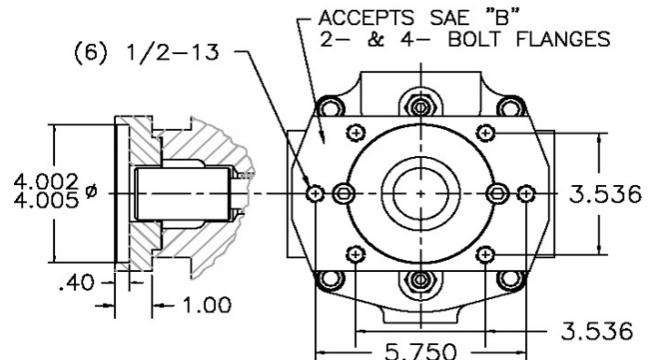

SAE SHAFT	DESCRIPTION
B KEYED	.875 ϕ , 1/4 SQ. KEY
B SPLINE	13 T, 16/32 DP

* AB SPLINE REQUIRES A .38" WIDE FLANGE EXTENDER