

300/4000 **SERIES**

**ATMOSPHERIC INLET AXIAL
PISTON PUMPS and MOTORS**

HARTMANN
PUMPS - MOTORS - CONTROLS

TABLE OF CONTENTS

General Characteristics

Ordering Information

Design Features & Benefits

General Information

- Operating Principles
- Fluid Recommendations
- Ratings & Capabilities

Allowable External Gear or Belt Force

Fire Resistant Fluids ("FR" Option)

Fixed Displacement Pumps & Motors PF/MF300 & 400

Variable Displacement Pumps & Motors

Flow Control Pumps:

External Handwheel Control PV310 & PV410

Pressure Compensated Pumps:

Standard (Setscrew) Control PV320 & PV420

External Handwheel Control PV321 & PV421

Remote (Pilot) Operated PV324 & PV424

Performance Curves, Typical

Load Sensing (Flow Compensator) PV325 & PV425

Options: Porting, Shaft, Mounting

300/400

SERIES

ATMOSPHERIC INLET AXIAL PISTON PUMPS

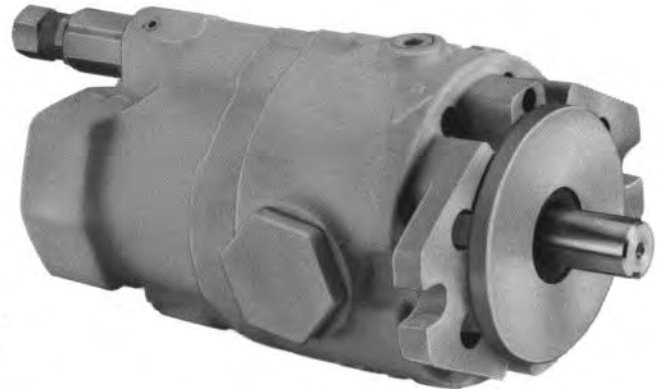

GENERAL CHARACTERISTICS (Theoretical)

Specifications (Theoretical)	300 Series		400 Series	
	Displacement, max.	3.2 in. ³ /rev.	52.0 ml./rev.	4.1 in. ³ /rev.
Flow @ 1800 rpm	25 gpm	94.6 lpm	32.7 gpm	123.8 lpm
Operating Speed				
Minimum	500 rpm		500 rpm	
Rated	1800 rpm		1800 rpm	
Maximum with atmospheric inlet (6 in. Hg.)	2400 rpm		2200 rpm	
Operating Pressure (varies with model)				
Minimum	0-400 psi	0-28 bar	0-400 psi	0-28 bar
Maximum, continuous	3000-4000* psi	207-276* bar	3000 psi	207 bar
With intermittent use up to	4000-5000* psi	275-345* bar	4000 psi	275 bar
Power Output				
Rated, continuous duty	58.0 HP	43.0 kW	57.0 HP	42.0 kW
	*Heavy-Duty, High-Pressure Models			

DESIGN FEATURES & BENEFITS

FEATURES:

A. Separate Valve Plate—Separate hardened alloy steel valve plate resists wear. Unidirectional designs include a precompression orifice from the discharge port to the approaching cylinder. This method allows a uniform, gradual pressure rise from inlet to outlet to minimize mechanical shock and the resultant noise. A decompression orifice communicates with the cylinder approaching the inlet port to the pump case. This decompresses the oil that remains in the cylinder after leaving the discharge port. This increases volumetric efficiency and promotes stiffer systems by providing a means to remove air-entrained oil from the circuit.

B. Forged Rotor—One-piece forged bronze rotor resists wear, pick-up, and fretting caused by fluid-borne contaminants or low-lubricity fluid conditions. Rotor is splined to permit axial motion to compensate for fluid film thickness and temperature changes.

C. Ball-Shoe Pistons—The ball of the piston knuckle joint is formed on the piston shoe. This reduces the overall piston length and the resultant side force on the cylinder bores.

D. Roller Bearings—Dual, heavy duty, tapered roller bearings support the drive end of the input shaft. They are lubricated by the hydraulic fluid and designed to accept external side loads normally encountered in belt-drive applications.

E. Reaction Plate Assembly—Heavy forged steel reaction plate assembly has a separate hardened alloy steel thrust plate, to distribute wear and reduce repair costs.

F. Dual Holddown System—Individual piston springs preload the entire piston assembly against the thrust plate. A fixed-clearance mechanical retainer assembly holds the piston shoes against the thrust plate. Compared to single-spring holddown systems, which retain only the piston shoe, this method reduces mechanical lash, wear of the piston knuckle, and related noise generation.

G. Opposed Control Pistons—Displacement changes are rapid and stable due to the high positioning force available from the line pressure operated controls. The opposed pistons hydraulically “clamp” the displacement changing mechanism for optimal delivery stability.

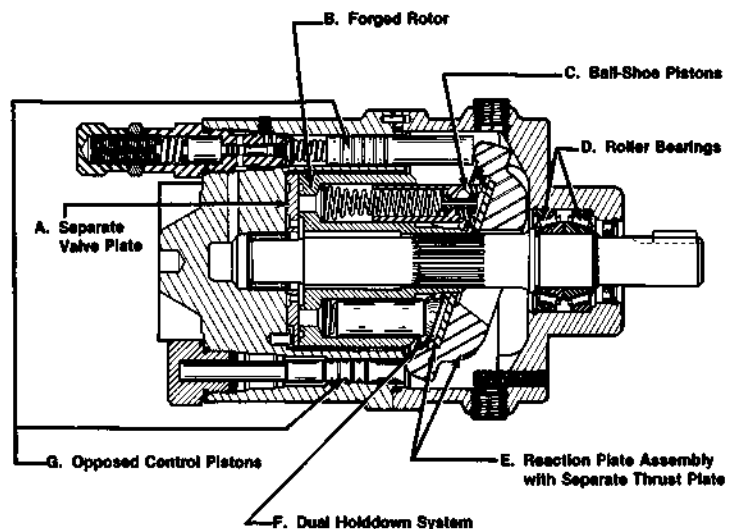

BENEFITS:

Lower System Costs

The high pressure capability of these units permit the use of smaller size system components to handle the same horsepower at lower cost. Heavy duty shaft bearings accept overhung loads, eliminating the need for a countershaft on most indirect drives.

Lower Operating Costs

High overall efficiencies and power-saving controls reduce power consumption and cooling requirements.

Extended Service Life

Tough alloy bronze mated to hardened alloy steels in the rotating group, and heavy duty bearings are used throughout the pump to provide long life operation.

Repairable

Designed to permit easy field service. All parts subject to wear are field serviceable.

Low Noise Levels

Preloaded pistons, unique port timing, and rigid case construction yield low noise levels (PV320 83.5 dBa at 1800 RPM, 4000 psi, 24 GPM).

300/400 SERIES GENERAL INFORMATION

OPERATING PRINCIPLES:

These pumps are of axial piston, inline design and are available in either fixed or variable displacement versions.

The drive shaft is splined to the pump rotor, which carries seven pistons located axially about its axis. Each piston has a shoe that is free to pivot and rotate. The shoes bear against a reaction plate, which is angled with respect to the axis of the pump. The port end of the rotor seals against the port plate with its two arcuate openings. These connect with the inlet and outlet port of the pump. The rotor is free to move axially to compensate for wear and fluid film variations caused by pressure and temperature.

During the inlet period of the pumping cycle, the piston assemblies are held against the angled thrust plate. A fixed clearance holddown plate rotates at shaft speed behind the shoes, positively preventing piston liftoff under adverse operating conditions.

The shoes bear against the cam surface of the thrust plate. The thrust plate rotates slowly in the reaction plate to distribute the effects of wear. Rotation of the shaft causes the pistons to reciprocate as they follow the cam surface to accept fluid from the inlet port and displace it to the outlet port.

The reaction plate angle determines the piston stroke and thus the displacement of the pump. This angle is fixed in fixed displacement units, and infinitely variable in the variable displacement units.

Wear is reduced to a minimum in these units through selection of optimal materials, unique shock suppression techniques, and hydrostatically balanced design. Hardened alloy steel parts mate with high strength bronze material for superior durability.

FLUID RECOMMENDATIONS

A. Petroleum Based Fluids

Viscosity*: Maximum at cold start — 5000 SUS
Maximum at full power — 300 SUS
Minimum — 100 SUS

*At 100°F (38°C)

Viscosity Index: 90 VI

The fluid recommended for use in these pumps and motors has a petroleum base and contains agents which provide oxidation inhibition and anti-rust, antifoam, and deaerating properties.

B. Fire-Resistant Fluids

There are applications which require fire-resistant fluids.

They will give good service if the system is originally designed for their use. Permissible fluids include: synthetics, water glycols and water in oil emulsions, although pump life can be shortened dependent on the fluid used.

Consult Hartmann Controls for written advice and for design requirements and warranty limitations for the particular fire-resistant fluid contemplated.

See page 7 for more information on the "FR" Series pumps.

RATING AND CAPABILITIES

All ratings shown in this designers' guide were computed under normal operating conditions, which insures maximum life for the average application using a high quality mineral base hydraulic fluid. Warranty is based on these ratings.

TO INSURE WARRANTY COVERAGE, consult Hartmann Controls for written advice before apply-

ing units in applications that require operation at other than rated levels.

In lieu of written advice from Hartmann Controls and compliance with this advice, NO WARRANTY SHALL APPLY.

ALLOWABLE EXTERNAL BELT OR GEAR FORCE VS. DIRECTION OF FORCE

B-10 Life = 5000 hrs.

1800 RPM

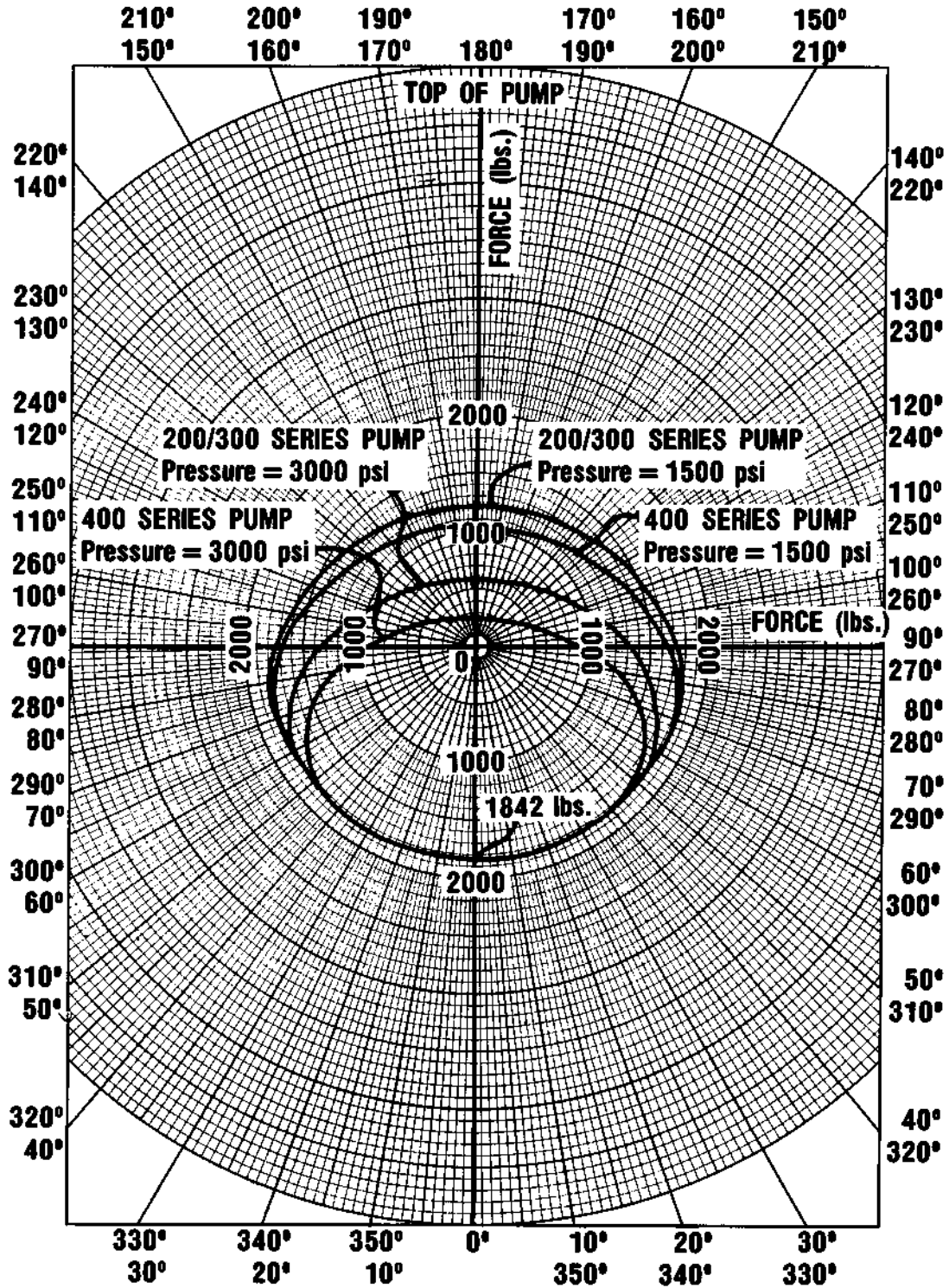

REMOTE PRESSURE COMPENSATOR VARIABLE DISPLACEMENT PUMPS

MODELS 324 & 424

The remote pressure compensator control is designed for those applications where frequent adjustment of the compensating pressure and/or multiple pressure control circuits is desired. It adjusts pump delivery automatically to meet system flow requirements while maintaining the preselected pressure.

The compensator pressure setting is determined by the setting of the pilot relief valve, located at a convenient position remote from the pump. When the pump discharge pressure is below the setting of the remote valve, fluid is ported through the compensator valve spool to the large control piston, stroking the pump. When the discharge pressure reaches the desired setting, the relief valve opens and the compensator valve opens reducing pump flow to maintain the set pressure.

The remote compensator can be used in a two pressure (hi-low) circuit by adding a two-way valve between the pilot line to the remote relief valve and reservoir. When the two way valve is open, system compensating pressure is determined by the spring setting in the compensator valve. When the two-way valve is closed, system pressure increases to the sum of the spring setting and the setting of the remote relief valve. Additional two-way valves and relief valves connected in a series between the pilot line and the reservoir can be included to obtain intermediate pressure settings. Distances between pump and control of 50 feet or less can be used without affecting pump response time. For systems that require distances from pump to control in excess of 50 feet, contact the factory.

System Diagram:

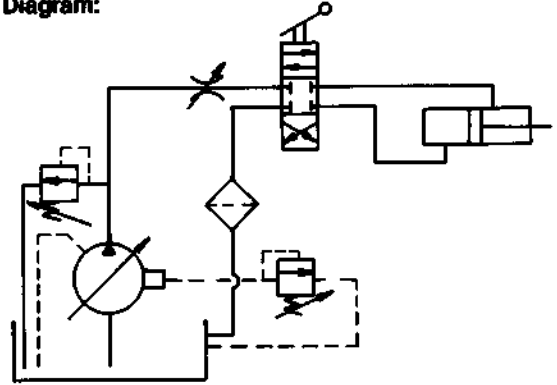

Relief valves are recommended in all systems and should be set at 10% over the desired compensator setting. In systems using accumulators or pressure compensated flow control valves, a check valve must be installed at the pump outlet port. This is desirable in all systems.

OPTIONAL ADJUSTABLE VOLUME — The maximum desired volume to be pumped can be controlled by the volume limit adjustment. This adjustment screw limits the maximum angle of the reaction plate to a predetermined maximum. (See page 22).

Drive Shaft Rotation

Pump	Rotation of shaft*	Oil Flow	Ports**	
			Inlet	Outlet
PV 324 & PV 424	R(CW only)	CW	A	B
	L(CCW only)	CCW	B	A

*As viewed from the front or shaft end.

**As viewed from the port end (nameplate up).

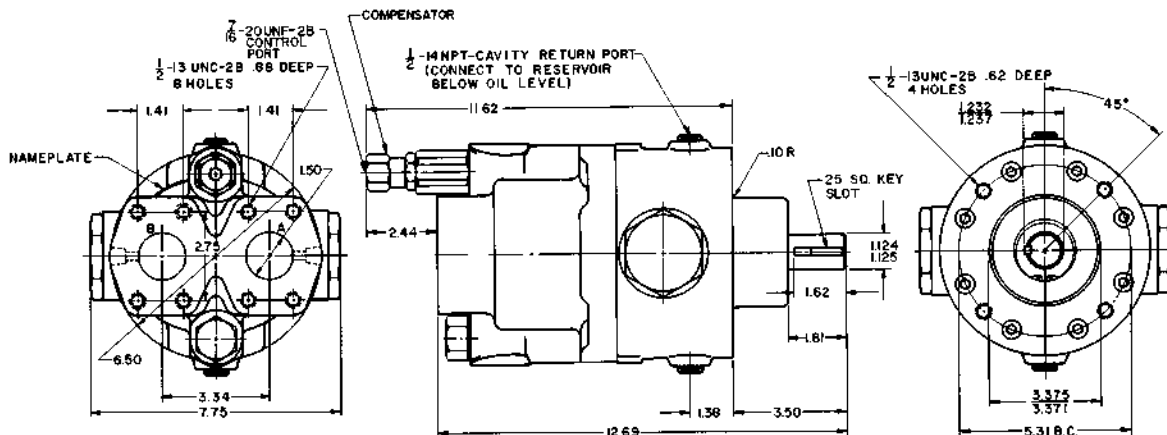

TYPICAL PERFORMANCE — MODELS 320/420

PV 320
1800 RPM
120° MOBIL DTE 26

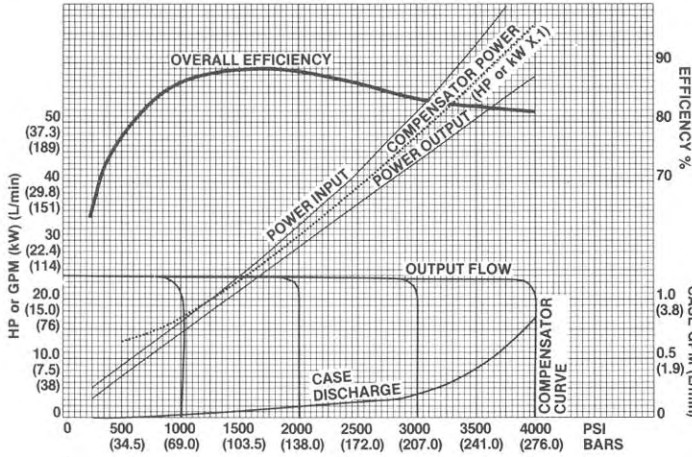

PV 320
2400 RPM
120° MOBIL DTE 26

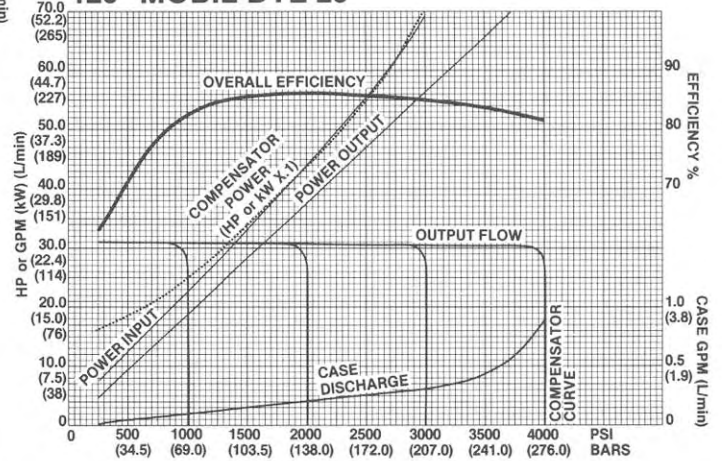

PV 420
1800 RPM
120° MOBIL DTE 26

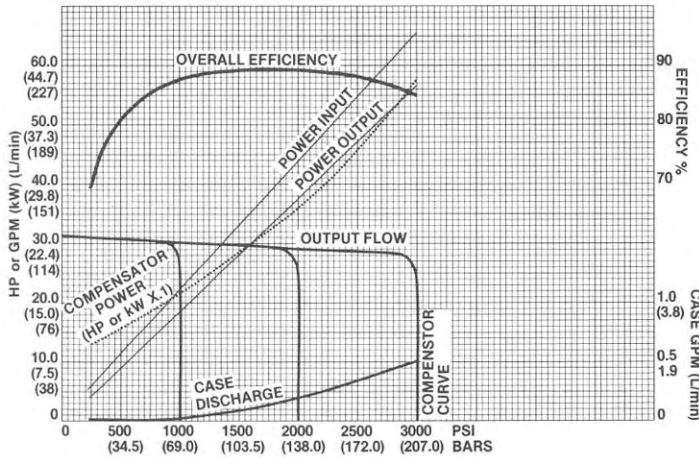

PV 420
2200 RPM
120° MOBIL DTE 26

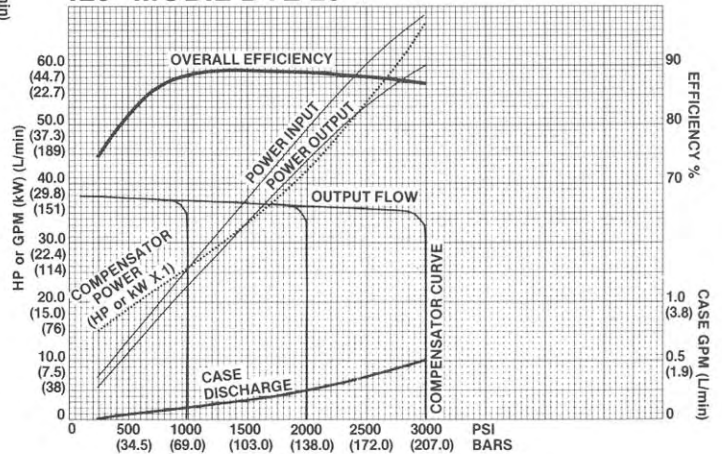

MOUNTING BRACKETS AND ADAPTERS
 (all mounting hardware included in each kit)

SAE C 2-Bolt Mounting Adapter, Kit No. 33824

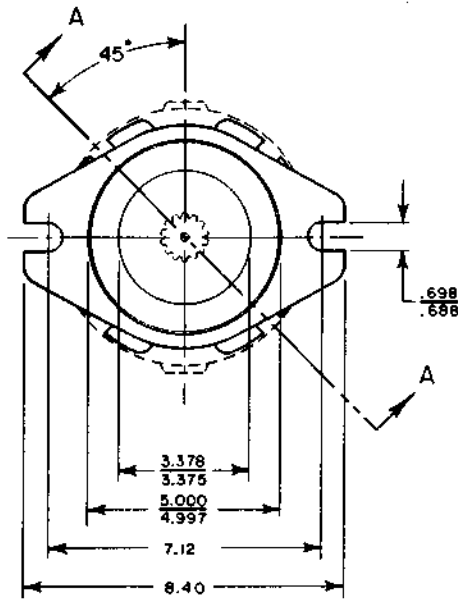
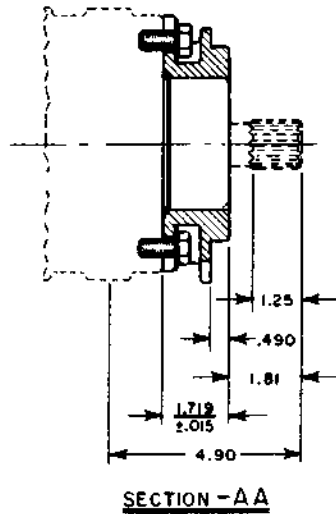

Foot Mounting Bracket, Kit No. 33269

