



604 Progress Dr. Hartland, WI 53029
Tel: (262) 367-4299 Fax: (262) 367-5645

Email: pumps@hartmanncontrols.com URL: <http://www.hartmanncontrols.com>

PVX FRAME 1

PVX 360 SERIES

(60 cm.³/rev.) (3.7 in.³/rev.)

VARIABLE DISPLACEMENT PUMP
AXIAL PISTON, SWASH PLATE DESIGN

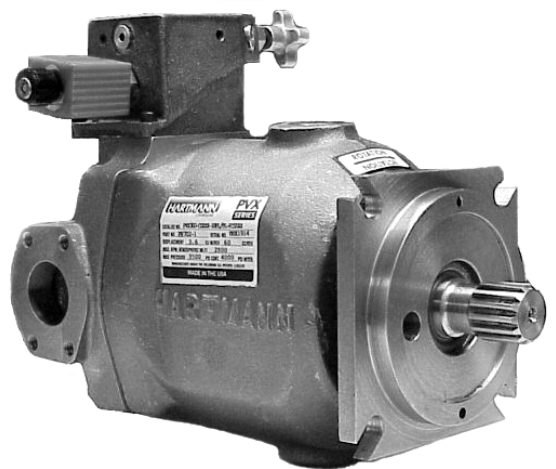
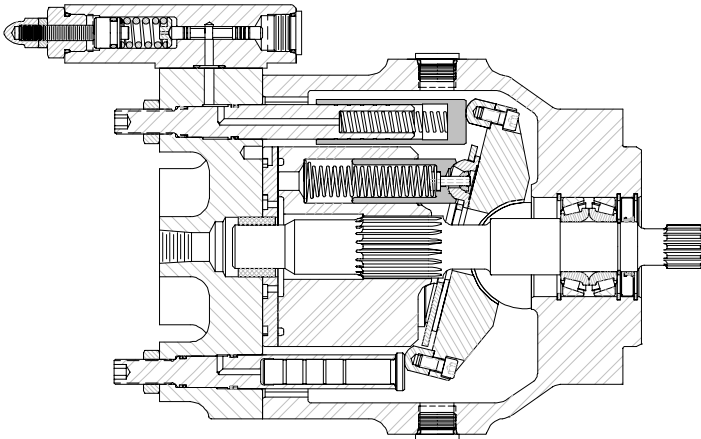

Features:

- Available with standard SAE 'B' or 4-bolt 'C' mount
- Multiple porting arrangement options
- Thru-drive option available
- Multiple control options including electronic
- Shaft speed up to 2800 rpm @ atmospheric pressure
- Special 'high water content' option available (on 'B' mount only)
- Simplistic design and service friendly
- Quiet operation
- Viton seals
- Extensive use of bronze
- Maximum and minimum flow stops standard

The versatile PVX 360 pump is designed for operation in both industrial and mobile applications. With continuous operating pressures ranging from 250 to 3500 psi, and speeds up to 2800 rpm at atmospheric inlet conditions, the rugged PVX 360 pump is designed for long and dependable service.

Check out our 3 years warranty!

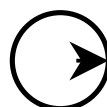

Pumps & Motors with a *hart of gold*™

Performance Data Obtained Using ISO 32 Oil @ 115° F

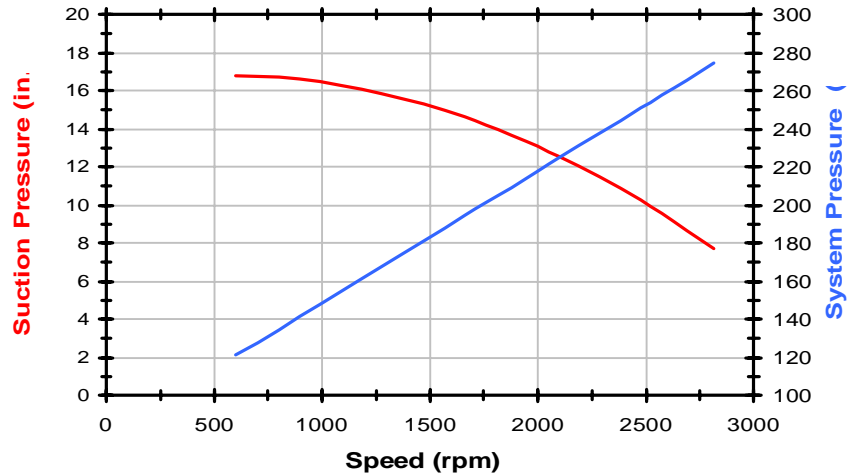
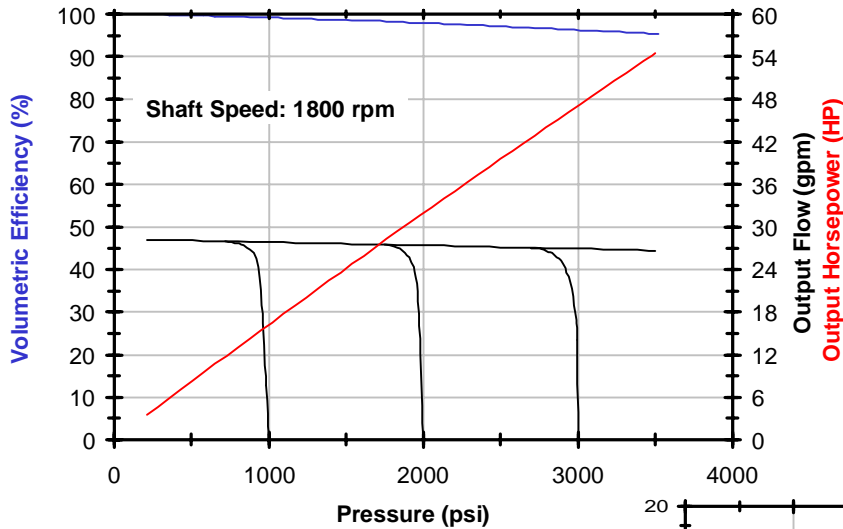

Operating Viscosities:

For petroleum-based fluids the optimal level is 150 SUS. For continuous operations, the level should range from 60 to 5000 SUS.

Filtration:

A minimum of 10 micron (abs.) filtration is required. A return line filter is preferred. Bypass filtration and suction filters/strainers are not recommended. Fluid cleanliness should conform to ISO 16/13 level.

Inlet Conditions and Piping:

The maximum temperature at the inlet should be 140° F. For higher levels consult factory. Inlet pipe, hose or tubing must be sized properly to limit resistance to < 6 in. Hg (3 psi). Suction hose, if used, must be wire reinforced to prevent its collapse. All connections must be air-tight.

Case Drain:

Two case-drain ports are provided on all models. The case-drain line must be properly sized to limit port back-pressure to < 25 psi.

Tandem Pumps:

All side-ported models can be modified to tandem pumps by adding a thru-drive shaft and a coupling. In addition, adapter flanges can increase or reduce flange pilots. Consult factory for details.

Pump approximate weight: 62 lbs.



PVX 360, Frame 1 PUMP SPECIFICATIONS

PVX	RATED PRESSURE	PEAK PRESSURE	MINIMUM PRESSURE
360	3500 lb/in² (241 bar)	4000 lb/in² (276 bar)	250 lb/in² (17 bar)

PVX	DISPLACEMENT	THEORETICAL FLOW @ 1800 rpm	MAXIMUM SPEED @ ATM. PRESSURE	MINIMUM SPEED
360	3.7 in³/rev (60 cm ³ /rev)	28.5 gal/min (107.9 l/min)	2800 rpm	600 rpm

PVX	INPUT TORQUE @ RATED PRESSURE	SHAFT SIZE	RECOMMENDED TORQUE LIMIT
360	2,039 in-lb (230.0 N-m)	SAE B SAE BB SAE C	1,450 in-lb (163.0 N-m) 2,200 in-lb (248.0 N-m) 3,700 in-lb (417.0 N-m)

◆ Input shaft torque should not exceed the total of front-pump torque and the added torque requirements of its rear-mounted units. To calculate input torque at conditions other than rated, use:

$$T_A = T_R \cdot (P_A / P_R) \cdot (Q_A / Q_R)$$

Where:

T_A=Actual torque, P_A=Actual maximum pressure, Q_A=Actual flow, T_R=Rated torque, P_R=Rated working pressure, Q_R=Rated flow

SELECTOR SYSTEM CHART

PVX

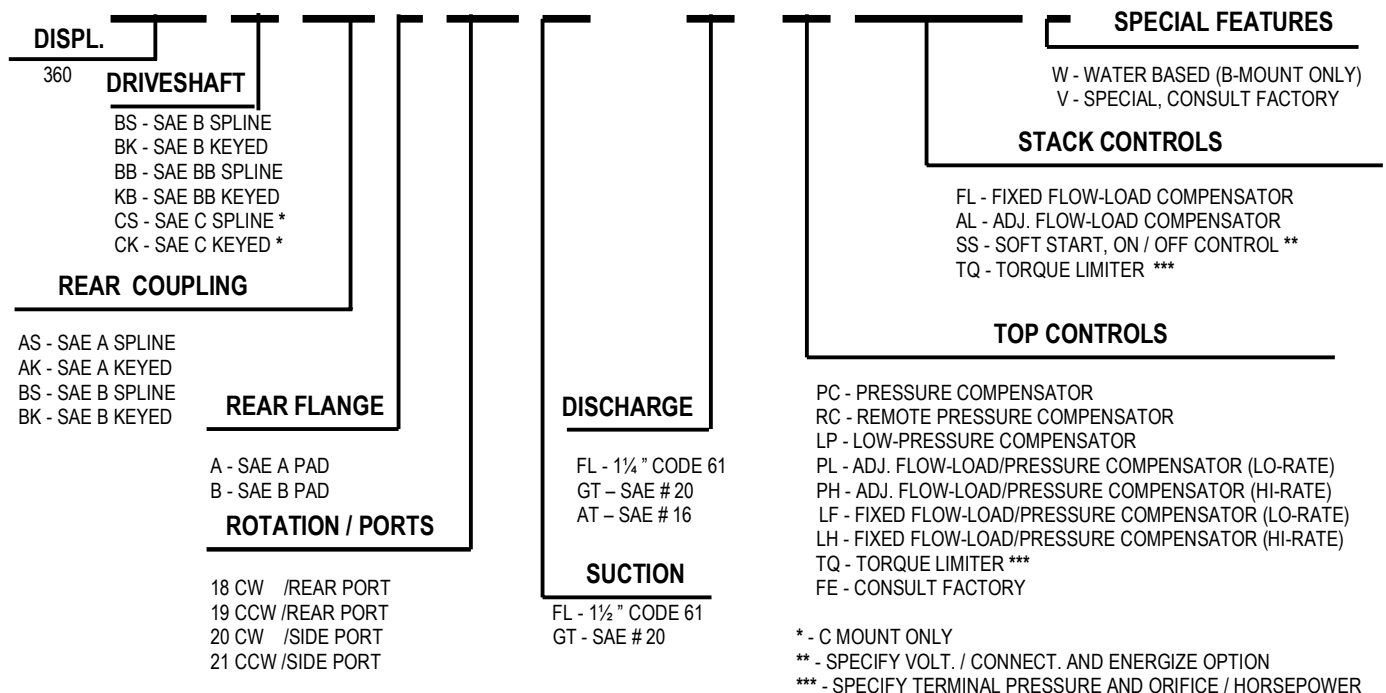

PVX 360, Frame 1 DIMENSIONS

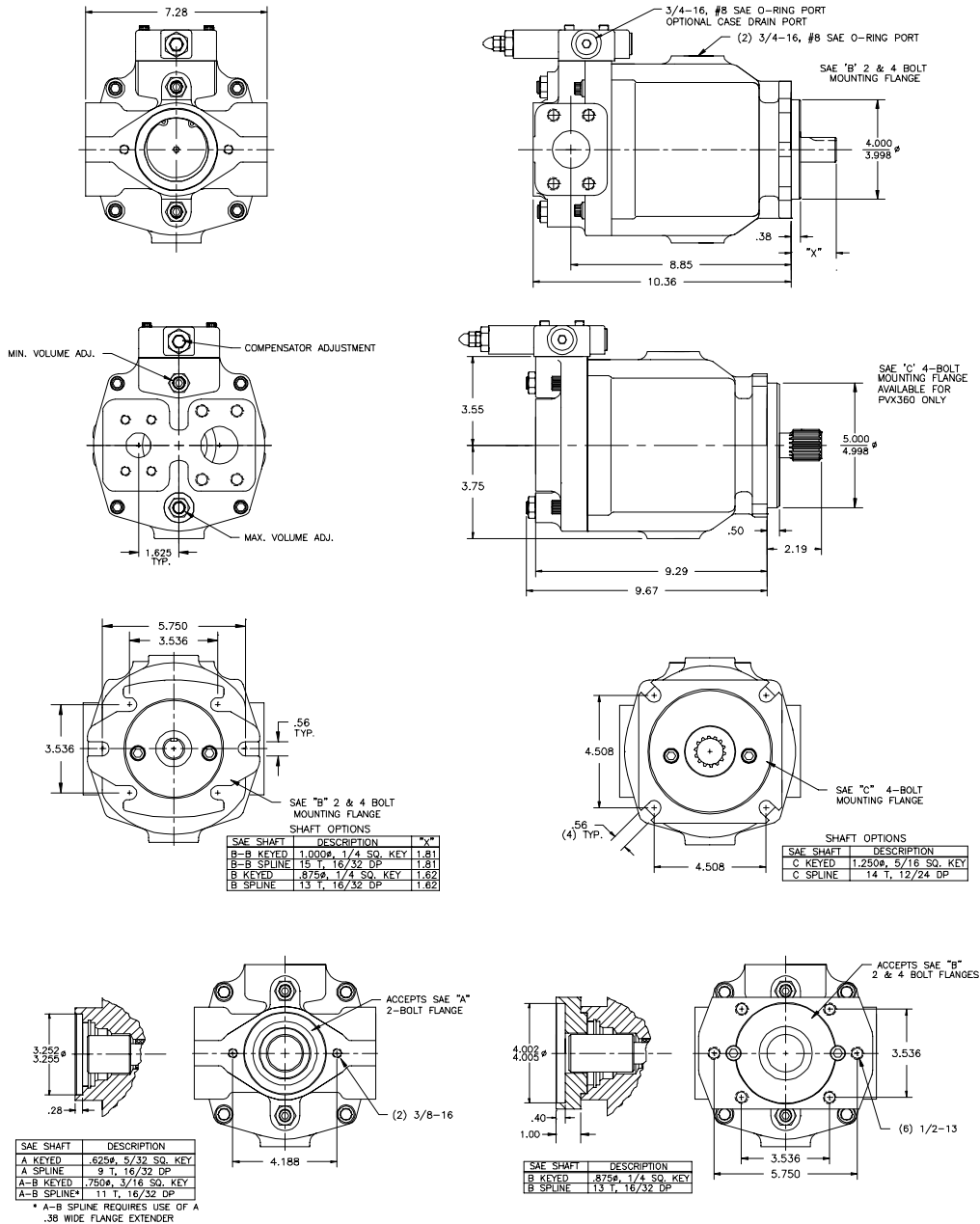

HARTMANN WARRANTY

Best in the business

All oil based fluid power products sold by Hartmann Controls, Inc. are warranted only to purchasers for resale or for the use in business or original equipment manufacture, against defects in workmanship of materials under normal use and service (rental use excluded), if notice of said defect is received by Hartmann at the factory within **36 MONTHS after installation or 42 MONTHS from the date of shipment** from the factory, whichever first occurs. Any product which is determined to be defective in workmanship or materials and returned to the Hartmann factory, shipping costs prepaid, will be repaired or replaced, at Hartmann's option. The cost of such repair or replacement shall be the exclusive remedy for any breach of any warranty, and Hartmann shall not be liable to nay person for consequential damages for injury or commercial loss resulting from any breach of warranty. Hartmann makes no other warranty, express or implied, including warranty for a particular purpose, or arising from course of dealing or usage of trade. No person including any dealer or representative of Hartmann is authorized to make any representation or warranty concerning the obligations contained in this warranty. Since no Hartmann fluid power products sales are made by Hartmann to consumers as defined In the Federal Consumer Products Warranties (Magnuson-Moss) Law, Hartmann makes no warranties to those defined as consumers in said Law.

*Supercedes warranties issued prior to September 1, 1996.

Hartmann = Reliability